



Gardner Denver

TRANSPORT SOLUTIONS

TV01 Compact

Electric Air Compressor



Next Generation Compressor Technology for Hybrid, Fully Electric & Fuel Cell Vehicles

Connect and go your vehicles with the new TV01 Compact electric air compressor package from Gardner Denver Transport Solutions.

The TV01 Compact is robust, lightweight, and highly efficient. The TV01 Compact is designed around today's needs for sustainable clean transport.

Building on the established advantages of our rotary vane technology, the TV01 Compact is the latest evolution in the TV Series. It continues to deliver outstanding performance and reliable operation, while offering a new space-saving design.

Technical Information

Flow Range: 110 to 260 l/min

Pressure Range: up to 12.5 bar

Voltage Options: 400V DC and 600V DC

Final Oil Content: (mg/m³) <5

Ambient Temperature Range: -20oc to +65oc

Compact

| Lightweight

| Small Footprint

| Easily Integrated



<https://www.gardnerdenver.com/transport>

Applications

- Pneumatic Door Operation
- Vehicles Suspension Systems
- Safe Operation of Central Braking Systems

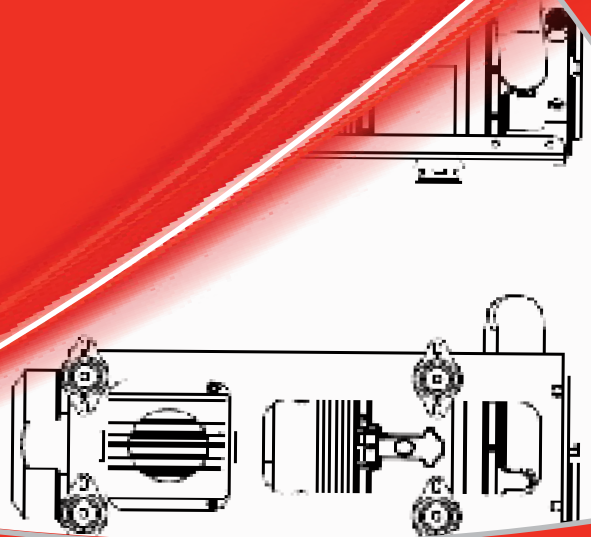

Features & Benefits

Compact & Lightweight Package

- Compact design with up to 48% package size reduction* offering space-saving installations, with a combined motor and inverter drive.
- Lighter package with up to 35% weight reduction*
- Cost optimized solution providing low life-cycle costs.
- Simplified solution, truly plug-and-play delivering fast and easy installations.
- Intelligent control with CAN/J1939
- Value Add for 24V to HV Conversion, including vehicle electronic savings.
- Value Add for ACIM Only to DC Power & Control

*Compared to the previous TV01 generation.

Pioneering Air System Modules for Advanced Electric Vehicles

Our proven experience and expertise as a manufacturer of Air System Modules allow us to deliver successful solutions for the most sophisticated electric vehicle applications. For example:

- Medium and large sized trucks
- Full-size single-decker & double-decker buses, articulated buses & Bus Rapid Transport (BRT) systems
- Door-to-door distribution vehicles
- Specialty vehicles (waste-collection vehicles, airport and off-highway)

