

Installation, Operating & Maintenance Manual

(Original Instructions)

DRUM

HYDRAPAK OIL COOLER

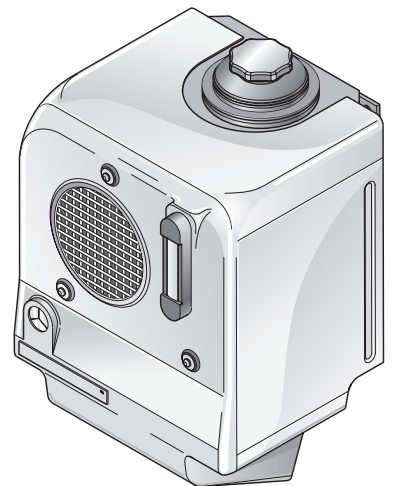
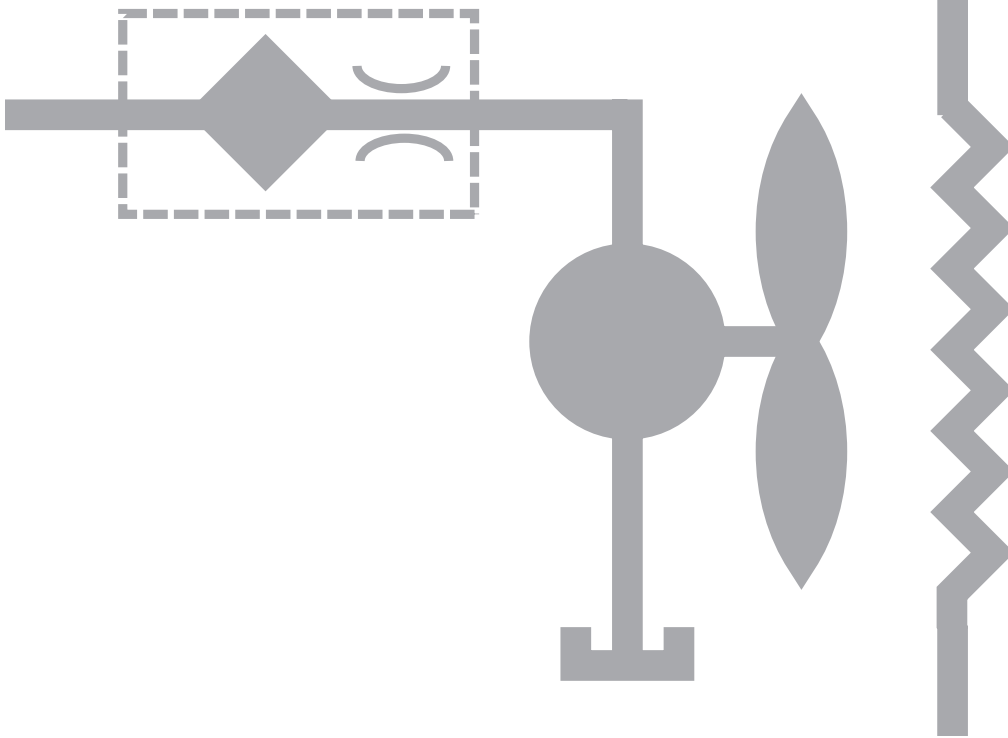

4991015003
September 2013

Contents

Chapter		Page
1	Health & Safety	
	Health & Safety	3
2	General	
2.1	Product general description	4
2.2	Identification.....	4
2.3	Available Models.....	4
2.4	Dimensions & Operating Environment.....	5
3	Installation	
3.1	General Instructions	6
3.2	Mounting Hydrapak	6-7
3.2	Pipe Connection Diagrams	8
3.3	Hydraulic System (Hoses)	9
3.5	Hydraulic Fittings	10
3.6	Operating Instructions	11
3.7	Pressure Relief Valve	12
3.8	Relief Valve Setting Procedure.....	13
4	Maintenance Instructions	
4.1	Schedule.....	14
4.2	Removing the outer cover	15
4.3	Changing the filter element	16
4.4	Fault finding.....	17-18
4.5	Spare Parts Diagrams	19-22

1

Health & Safety

READ THE WHOLE MANUAL BEFORE COMMENCING INSTALLATION.



Static electricity

Any equipment must be installed in accordance with prevailing local earthing legislation.



Hydrapak

The Hydrapak has internal moving parts some of which may be accessed through the air inlet and outlet apertures. Do not place any objects into these apertures as personal injury could result.



Noise

Gardner Denver Drum's own noise tests show maximum noise levels to be typically less than 85dB(A). Other truck / equipment noise levels are likely to be greater.

2 General

2.1 Product General Description

The Hydrapak is a lightweight, compact oil cooler combining the reservoir, filter, control and safety equipment required in a hydraulic system within one assembly. This replaces large, heavy oil tanks and separate ancillaries.

The compact shape and size of the cooler make it ideal for mounting in small spaces on any chassis.

All variations can dissipate 8kW of heat for a 40°C temperature rise in a 45°C ambient automatically (without the need to adjust the fan speed).

All versions contain the following integral equipment:-

Oil reservoir (11 litres)

Cooling fan, radiator and hydraulic fan motor

Relief valve

10 micron filter (return) Rating = 10 Beta 2

Easily replaced paper filter element

Filter / radiator bypass valve

Oil level sight glass

Filter blockage indicator

Suction elbow and pipe kit

Compact size = 340(W) x 607 (H) x 375(D) mm

Low weight = 17kg (dry)

Low oil capacity = 11 Litres

After mounting, the installer simply has to connect the cooler to the hydraulic pump and motor without sizing / arranging any other equipment.

2.2 Identification

The body number of the machine is shown on the body number label which is located on the underside of the Hydrapak on the polyhydron block.

2.3 Available Models

The Hydrapak is available in two pressure variations (200 and 300 bar maximum), and three flow versions (60,100, and 140 litre/min).

General

2.4 Dimensions & Operating Environment

Dimensions

See Fig 1a.

Operating environment

The permissible/foreseen operating environment is as follows:

Ambient temperature range	-30 to +45°C
Resistant to tropical rain in operation and transit	
Truck Mounted, Worldwide, All seasons	
Heat dissipation = 8kW for a 40°C Temp Rise	

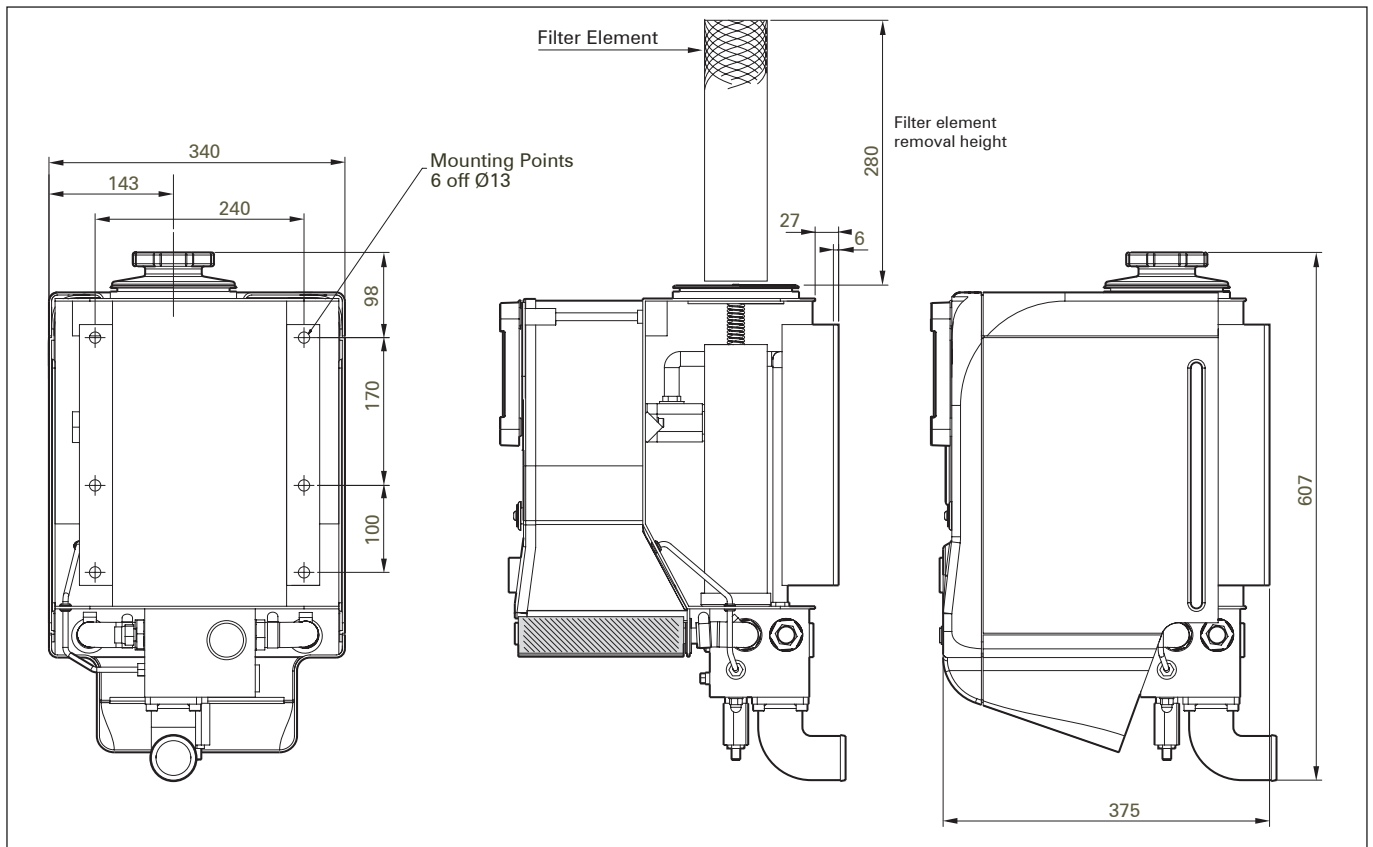

Fig 1a. Hydrapak general dimensions

3 Installation

3.1 General Instructions

Handling- The bare machine weighs 17Kg, therefore it is recommended that the machine is lifted with a suitable crane & sling. The machine must be lifted using the mounting points provided.

Storing- Store the unit in a dry, heated building. Handle the machine with care.

3.2 Mounting the Hydrapak

The new Hydrapak has 6 mounting points.

When installing the Hydrapak use holes 1, 2, 5 and 6.

When replacing older Hydrapak 2's with a Hydrapak, holes 1,2,3 and 4 are used but holes 5 & 6 may also be used for extra support. This makes inter-changing units easier when installing. See Fig 1b.

NOTE

Use 4 mounting points when installing the Hydrapak.

NOTE

Anti - Vibration pads should be used to isolate the cooler from vehicle vibration.

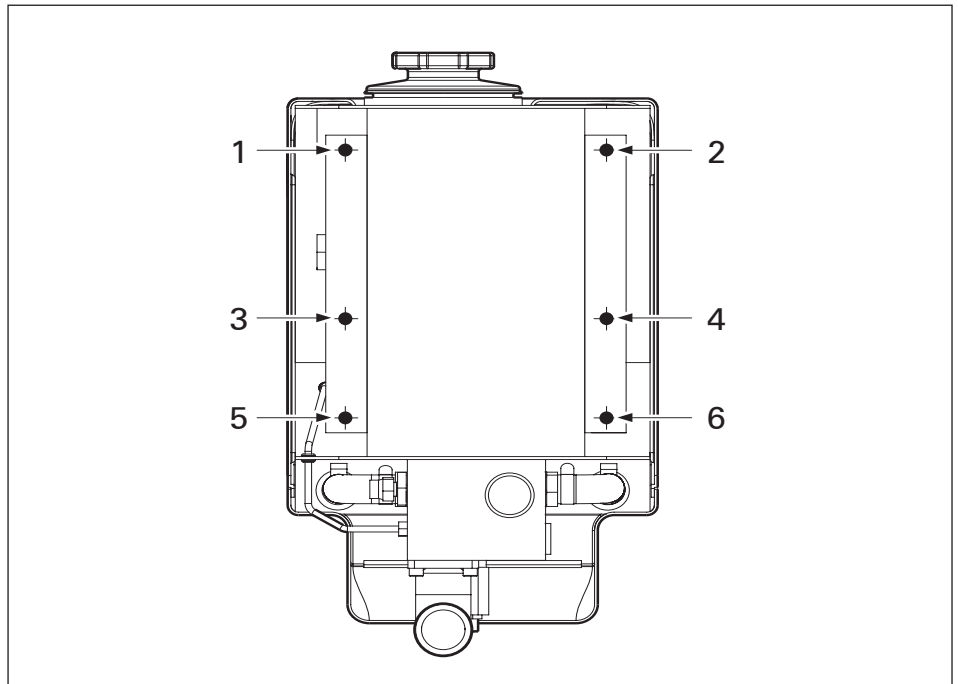
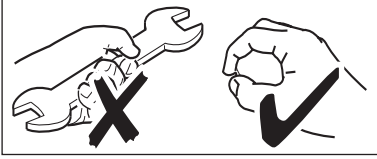

Fig. 1b. Mounting points.

Installation

CAUTION

Do not use excessive force when tightening the Filler Cap.



CAUTION

When the Hydrapak is to be used on cryogenic's, specialist hydraulic oils are used. The Motor supply hose should be changed accordingly.

See page 19 & 20 for correct part number.

NOTE

Do not distort tank when fitting, ensuring tank is secured using Anti-Vibration pads as illustrated.

1. Allow a minimum space of 280 mm above the Hydrapak filler cap to allow removal of the filter element when servicing.
2. When refitting filler cap, only tighten by hand. Do not use excessive force as this will cause the tank to distort.
3. During installation it is important to make sure that the air inlet and outlet ducts (shown below Fig 2) are not obstructed, allowing a free flow of air for maximum cooling.
4. Typically ISO VG46 hydraulic oil will be suitable but the correct viscosity for the hydraulic pump and motor (see manufacturers instructions) will also suffice for the Hydrapak. Ensure that the oil level coincides approximately with the mid point of the sight glass. Run the unit for 1 minute then top up the oil level if necessary.
5. When the Hydrapak is sharing the same mounting uprights with a compressor it is recommended that a deflector plate is installed to divert the hot air discharged away from the compressor. See Fig 2.

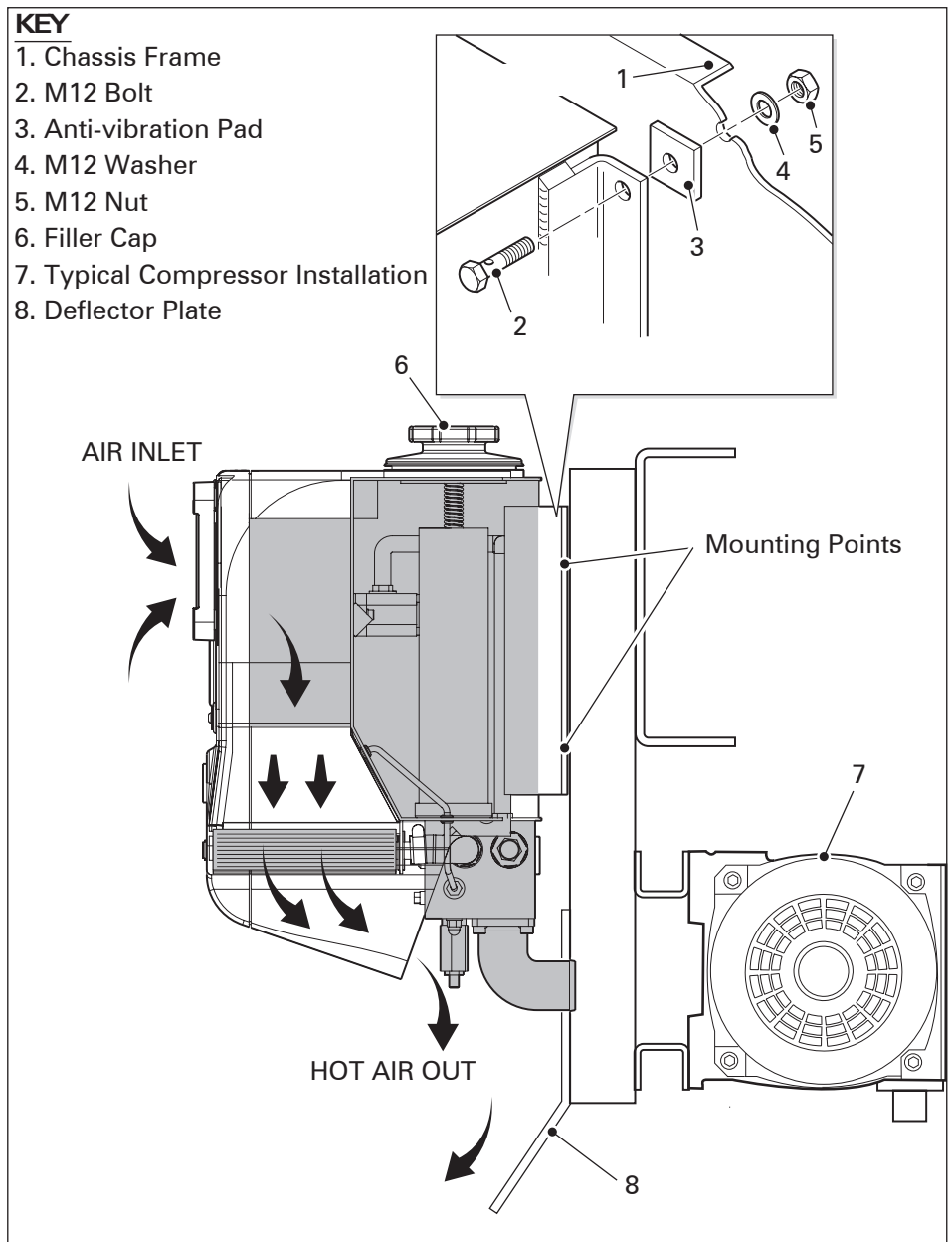

Fig. 2 Airflow direction incorporating typical compressor installation.

Installation

3.3 Pipe Connection Diagrams

Fig 3a shows typical installation. Fig. 3b shows a typical tractor/trailer installation with non-spill couplings.

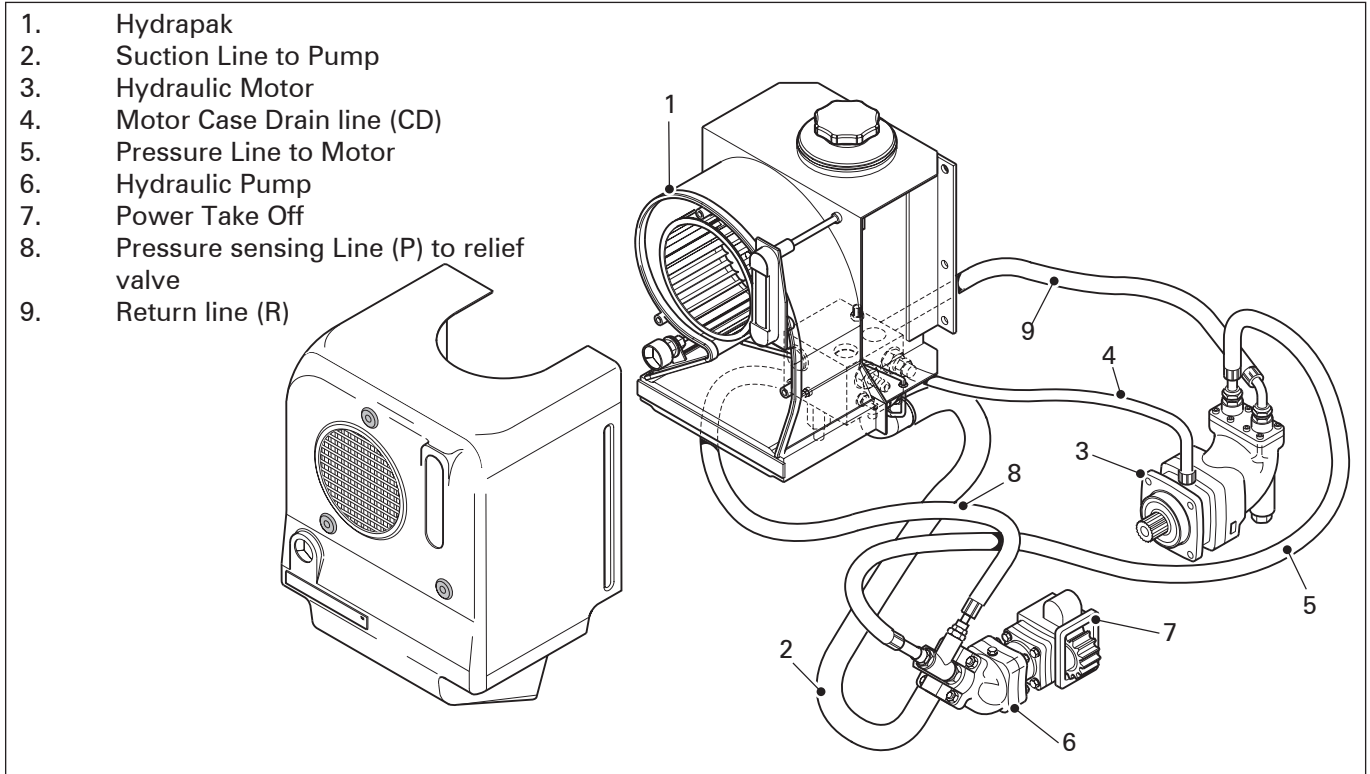

Fig. 3a Typical Installation

NOTE



When installing the hydrapak and hydraulic system, ensure that the pump and motor are mounted below the oil level of the Hydrapak reservoir.

10. Non-spill Couplings

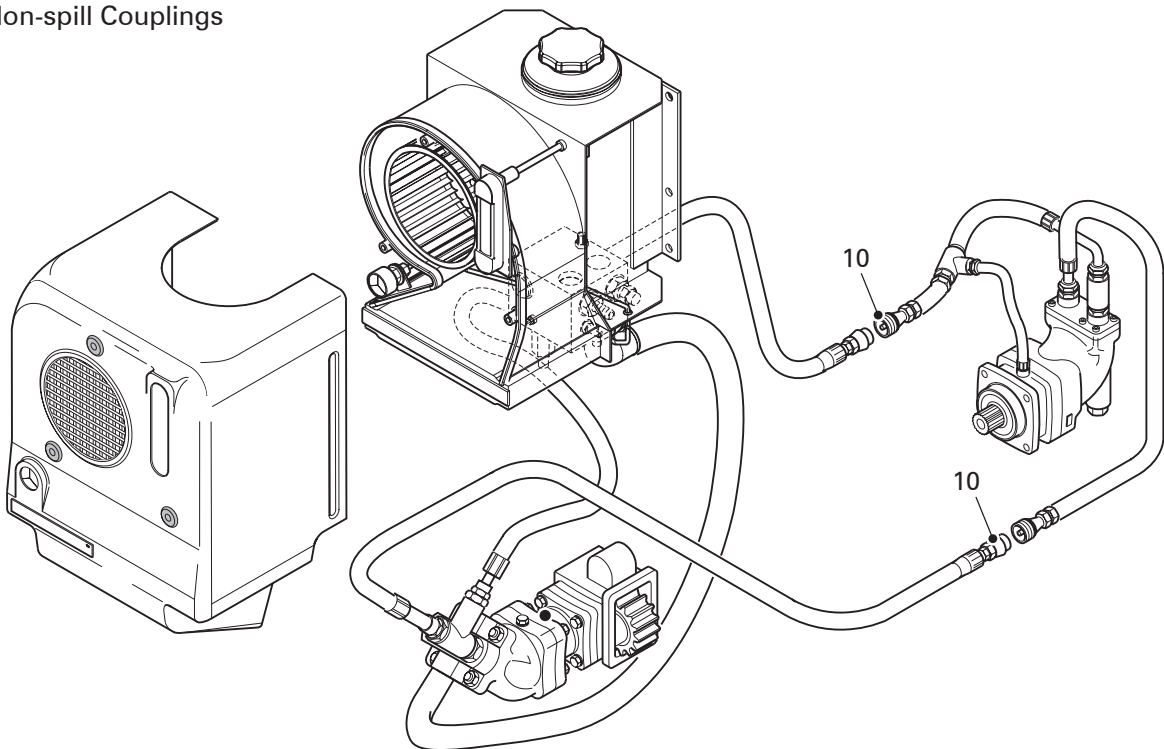

Fig.3b Tractor / Trailer installation

Installation

3.4 Hydraulic Hoses

Always make sure that any Hydraulic Hoses fitted into the Oil Cooler system are of the correct length to suit the positioning of the equipment being installed.

Allow for the movement of the PTO/Gearbox in relation to the Hydrapak when fitting the hydraulic hoses. See Fig 4, a and b.

CAUTION

DO NOT Install hydraulic hoses that are too long and may 'kink' when fitted.

CAUTION

DO NOT Install hoses that are too short and will be stretched when fitted.

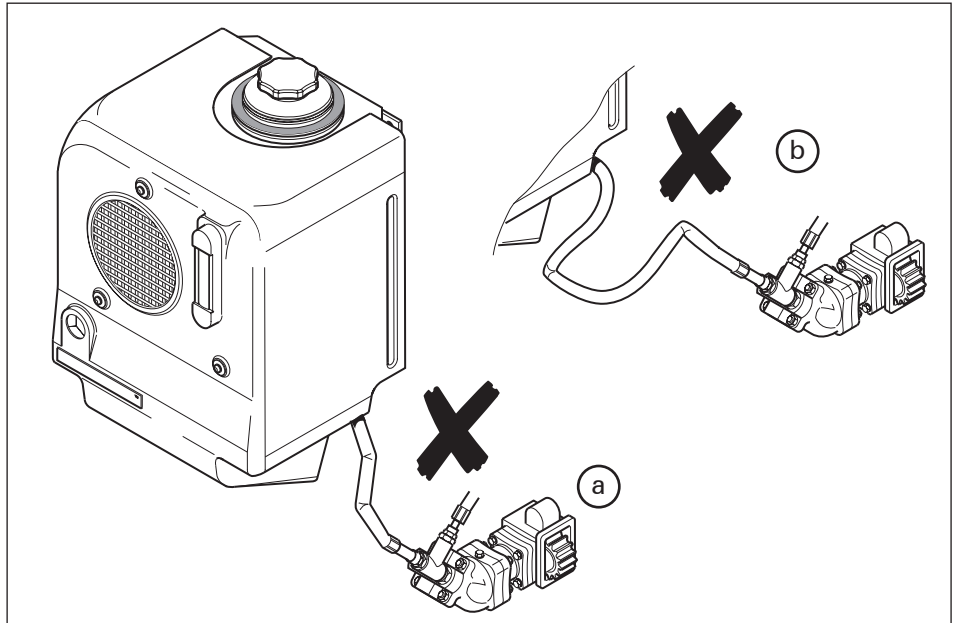

Fig. 4a. Hose Lengths too short 4b. Too long.

NOTE

The Hydrapak body must not be distorted or heavily stressed when mounting.

NOTE

Install the Hydrapak a safe distance away from the vehicle exhaust or other heat producing equipment. See Fig 5.

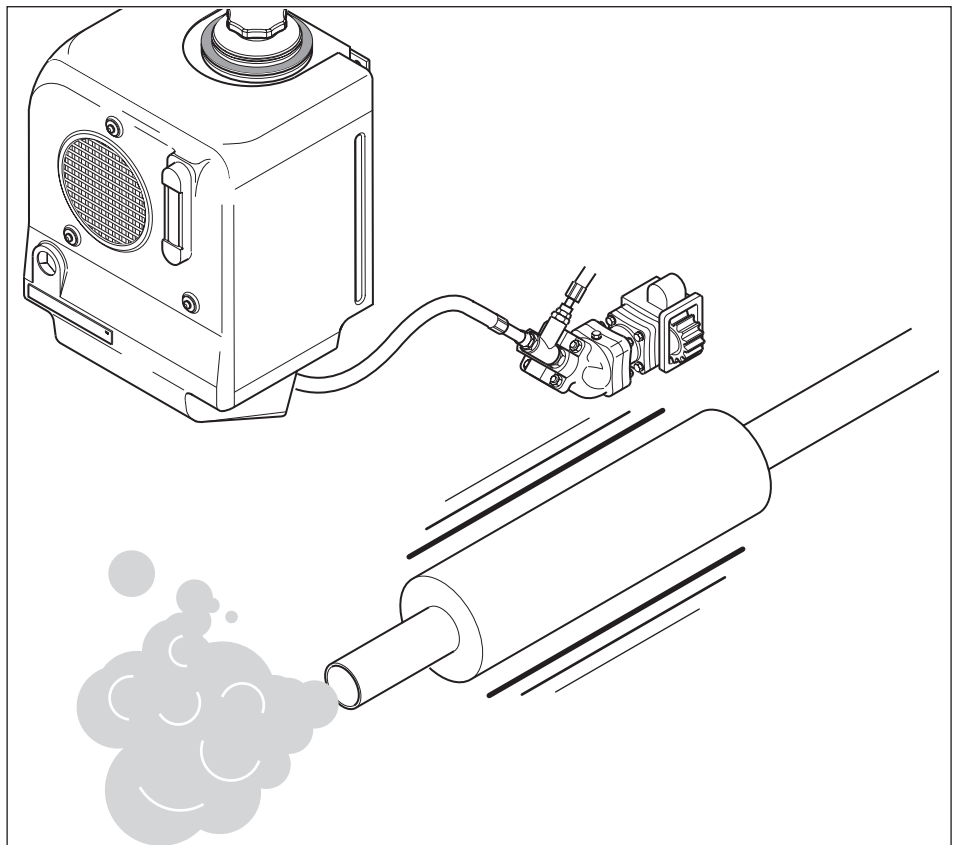

Fig. 5 Vehicle exhaust / heat producing equipment

Installation

3.5 Hydraulic Fittings

Leakage from any hydraulic fitting could cause air to be drawn into the system, which may cause damage to the hydraulic equipment.

Hose and end fittings should be of the appropriate pressure ratings :-

- SAE 100R2 - Low and Medium Pressure Hose
- SAE 100R10 - High Pressure Hose

Only use crimp hydraulic fittings with high pressure hose. Always use the correct size fittings.

The suction elbow can be orientated in any of three positions to accommodate different pipe layouts.

See Fig 6 for schematic layout.

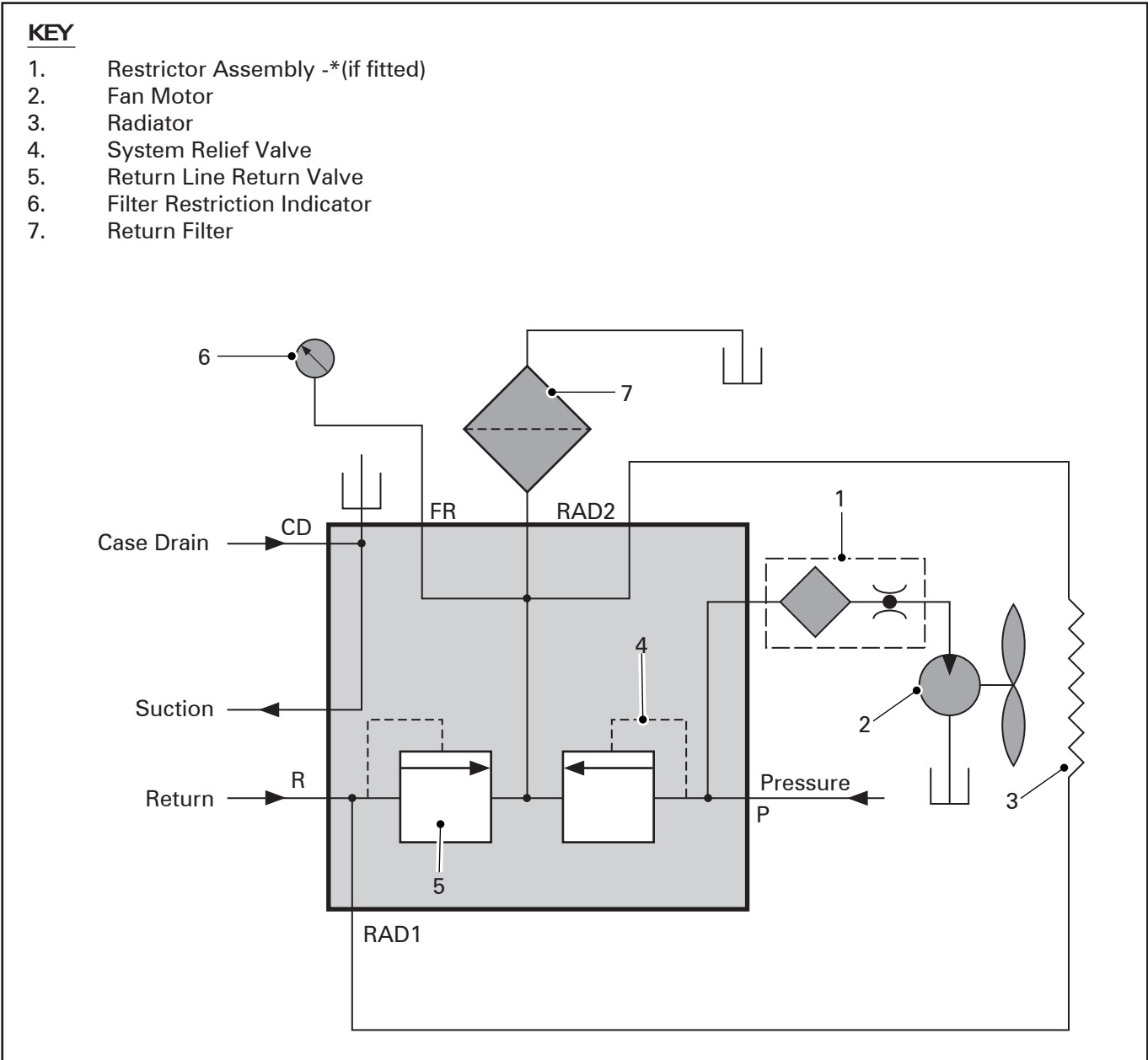

Fig. 6 Schematic Diagram

Installation

CAUTION

Grease or dirt must not be allowed to enter the internals of the machine.



It is recommended that ear protection is worn during vehicle testing.

3.6 Operating Instructions

Please read thoroughly before operating the system.

Noise

Tests conducted by Gardner Denver Drum show noise levels are significantly less than 85dB(A).

Safety

Do not operate the Hydrapak with the outer cover removed.

Visual Checks before Starting the System

Make sure any non-spill couplings (if fitted) are correctly connected.

Starting the System

1. Ensure the handbrake is applied.
2. If a selector valve or reverse flow valve is fitted, select the neutral position.
3. If hydraulic speed control is fitted, this should be fully open.
4. Check oil level. This should be on or slightly below the maximum level on the sight glass.
5. Depress the clutch and engage the PTO, release the clutch slowly.
6. Operate the selector valve (if fitted) for desired rotation.
7. Close the speed control valve (if fitted) to direct the hydraulic oil through the motor.
8. If a hand throttle is fitted, gradually increase to the required speed.

Stopping the system

1. Reduce engine speed to idle and return all control valves to the neutral position.
2. Disengage the PTO.

NOTE

A filter blockage indicator gauge on initial start up, (when cold), may point to the red sector (filter on full bypass). This is normal due to the high viscosity of oil when cold. When the system has warmed up the gauge should not remain in the red sector.

If the gauge remains in the red sector after warm up, the filter element must be replaced. See section 4.3.

IF IN DOUBT CONSULT A GARDNER DENVER DRUM REPRESENTATIVE.

Installation

3.7 Pressure Relief Valve

The working pressure of hydraulic drive systems is dependant on the installation and the load upon the system.

Although the normal working pressure range of the Hydrapak is 80-200 bar (LP) and 200-300 bar (HP version) the units are supplied with the relief valve preset to allow operation up to 180 bar (LP) and 280 bar (HP version).

If there is a need to increase/decrease these settings up to the maximum working pressure or reduce them to protect sensitive hydraulic equipment, follow the instructions in section 3.8.

To set the relief valve, a pressure gauge and a throttle valve must be connected into the pressure lines as shown in (Fig 7). Refer to Fig 8 for Relief Valve setting.

For the best protection, the relief valve should be reset to the maximum working pressure +30 bar on all hydraulic systems.

NOTE

Setting/adjusting the relief valve should only be carried out by a competent person with the correct equipment.

KEY

1. Hydrapak
2. Suction Line to Pump
3. Hydraulic Motor
4. Motor Case Drain Line (CD)
5. Pressure Line to Motor
6. Hydraulic Motor
7. Power Take off
8. Pressure Line (P)
9. Return Line (R)
10. Polyhydron Block Assembly
11. Pressure gauge
12. Throttle valve

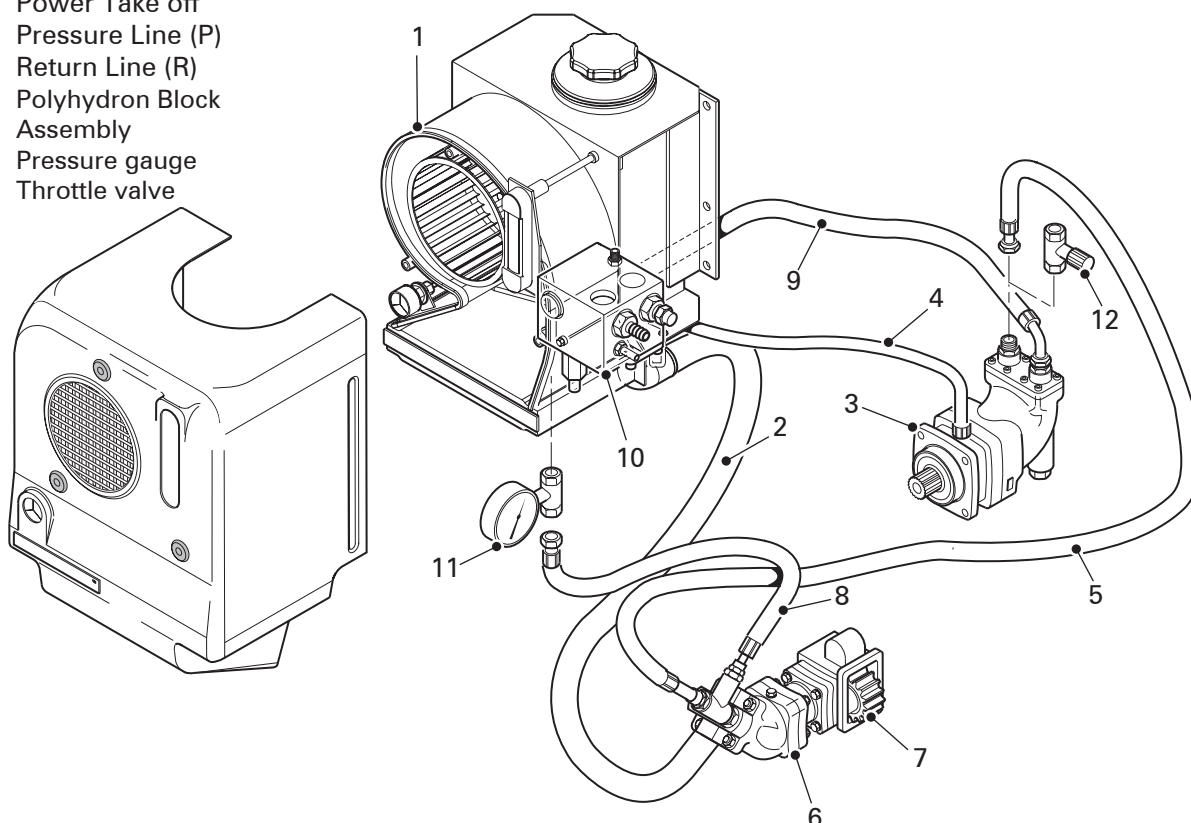

Fig. 7 Typical system layout

Installation

3.8 Relief Valve Setting Procedure

CAUTION

At high operating pressure the system will heat up rapidly. Make adjustments quickly then re-open the Throttle Valve

After draining the system and inserting a throttle valve and pressure gauge into the system (see fig 7):-

1. With the throttle valve fully open, run the system under load at normal operating speed and measure the normal working pressure.
2. Fully close the Throttle Valve to increase the pressure in the system. The drive motor will stop and the relief valve will go on full by-pass.
3. Using a 17mm spanner, loosen the locking nut on the relief valve adjusting screw (item 5).
4. Insert a 3/16" allen key (item 4) into the adjusting screw (item 5) and rotate as shown in an anti-clockwise direction to increase the by-pass pressure so that it is 30 bar above the normal working pressure.(Fig 8).
5. Drain the system then remove throttle valve and gauge (Fig 7 Items 11 & 12).

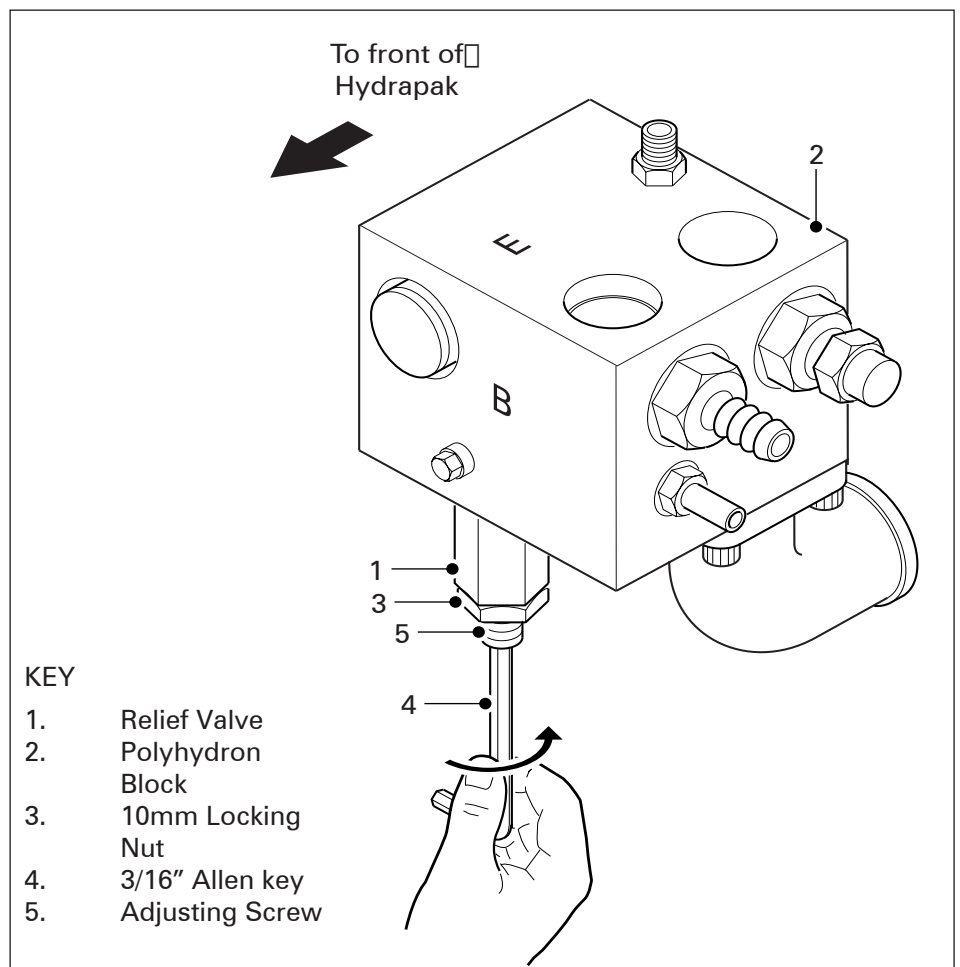

Fig. 8 Setting Relief Valve

4 Maintenance

4.1 Schedule

Always ensure the Hydrapak and hydraulic system are well maintained by following the maintenance instructions outlined below:

Every Day

- Check the reservoir oil level and top up if necessary.

First 50 hours

- For best practice and to maximise the life of system equipment, the hydraulic oil should ideally be changed for the first time.

Every 3 Months

- All bolts attaching the PTO to the gearbox, the pump to the PTO and the motor to the cargo pump are to be checked and tightened where necessary.
- Check for external damage and possible bulging of hoses under pressure. Replace worn hoses.
- Check for oil leaks in the system and tighten the pipeline connections where necessary.
- Check the reservoir oil level and top up as required.
- Check the radiator for dirt and possible blockage. Blow clear using compressed air.

Every 9 months

- Replace Filter Element.

Every 12 months

- Replace hydraulic oil. See page 7, point 4

Suction Hose

Special attention should be paid to the suction hose, Hydrapak to hydraulic pump. A leak due to a damaged or loose connection will allow air to be drawn into the system when it is operating and very quickly damage the pump. The suction hose must be able to withstand vacuum conditions up to 6" Hg.

Power Take Off, Pump and Motor

Refer to manufacturers recommendations.

NOTE



If air is drawn into the system it may cause damage to the hydraulic equipment.

Maintenance

4.2 Removing The Outer Cover

1. Unscrew and remove the 3 x M6 button head screws (item 2) and washers (item 3) from the front face of the outer cover.
2. The cover is now free to be pulled away from the aluminium tank Fig. 9.

NOTE

Filler cap no longer needs to be removed to take the outer cover off.

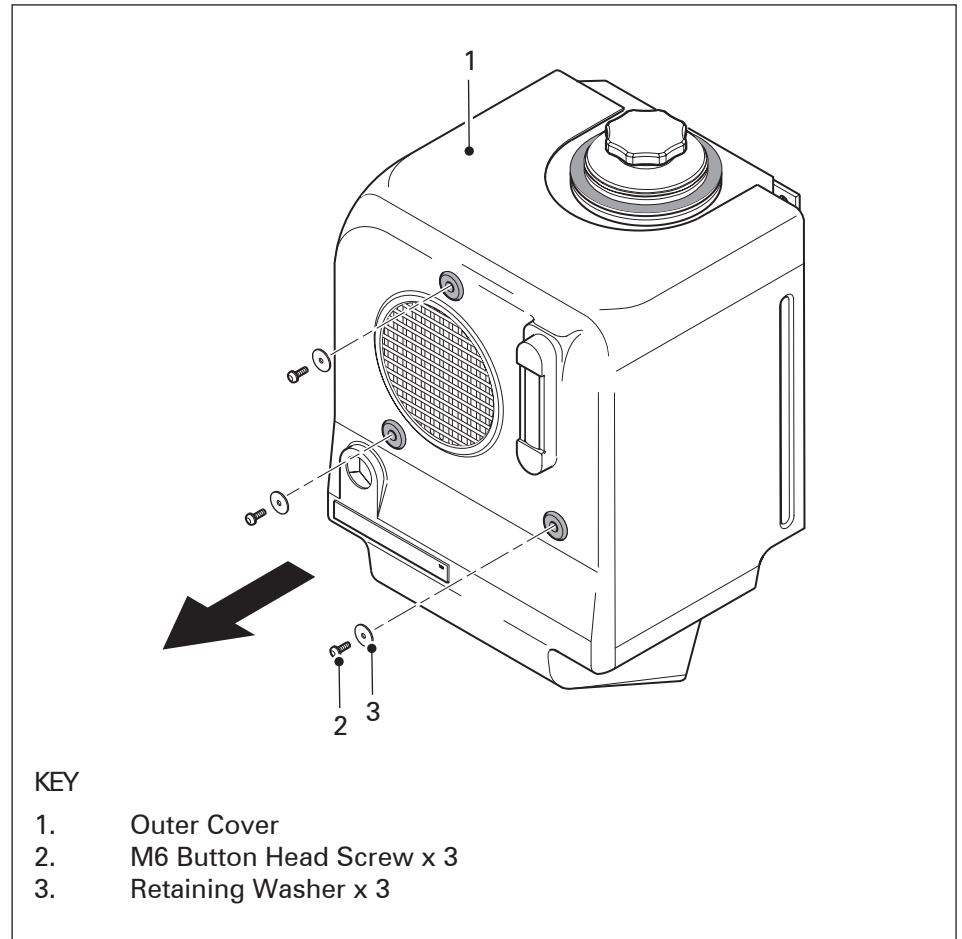

Fig. 9 Removing the Outer Cover

Maintenance

CAUTION

Take care not to drop any components or contamination into the tank.

CAUTION

Spring tension is released during this operation.

NOTE

When replacing the new filter element, ensure it is located into the housing at the bottom of the tank.

CAUTION

When re-fitting the Filler Cap, do not use excessive force. Hand Tight only to avoid distortion of the tank.

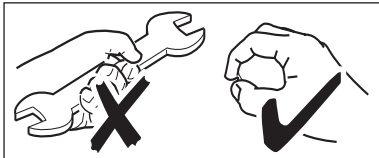

4.3 Changing The Filter Element

The life expectancy of the filter element is approximately 9 months. Gardner Denver Drum recommends that the filter condition is checked on a regular basis.

The cooler is fitted with a filter condition gauge (6) which is located at the front of the outer cover of the Hydrapak. When the needle of the gauge has reached the 'Red' section of the gauge the filter element will need changing.

1. Unscrew Filler Cap (1) and remove, then unscrew and remove filter retaining nut (2).
2. Remove Strainer Disc (3) from the sealing ring and remove the spring (4) located on top of the filter element .
3. Withdraw the filter element (5) from the Hydrapak reservoir. The filter is a non-serviceable item and must be replaced at the end of its service life.

Re-fitting a new Filter Element is a reversal of the above.

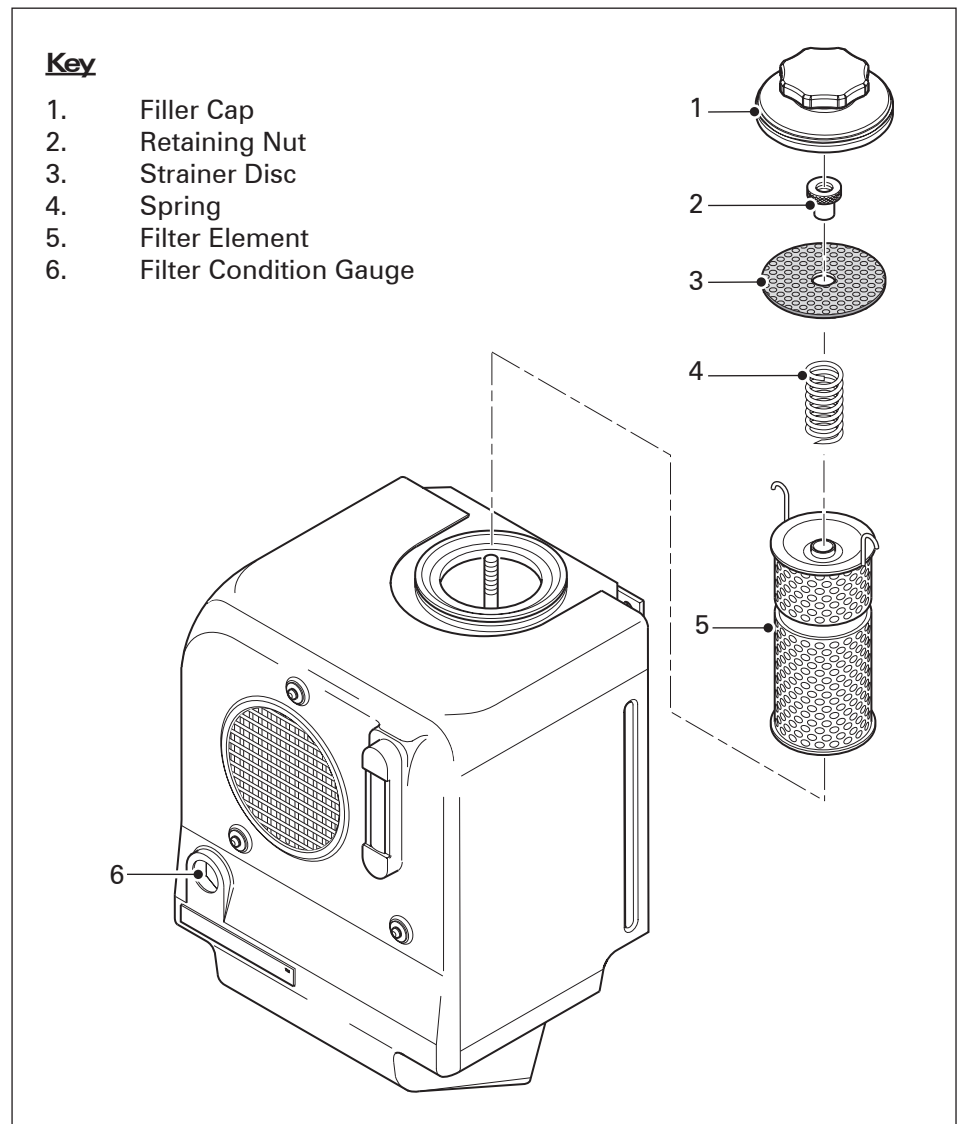

Fig. 10 Changing the Filter Element

Maintenance

CAUTION



When performing any type of maintenance or fault finding, ensure all rotating parts etc. are guarded or isolated for inspection.

NOTE



Unless all the components of a functioning hydraulic system are kept in a good working condition, operational problems are likely to occur.

4.4 Fault Finding

1. Noisy system	
Symptoms	Remedy/Solution
a. Cavitation of pump due to :-	
Low oil supply	- Top up oil
Incorrect grade of oil	- Replace with correct grade oil.
Suction line restriction	- Remove restriction
Sharp bend in suction line	- Modify design / line length
b. Air entering system due to :-	
Leakage in suction line	- Inspect and tighten pipe connections
Low oil level	- Replenish / Top up
Leaking packings, pump shaft	- Check and replace as necessary seals etc.
c. Mechanical errors due to :-	
Worn or damaged pump	- Repair or replace pump
Worn or damaged motor	- Repair or replace unit(s)
Failure of P.T.O.	- Repair or replace as necessary
d. Vibrating pipes due to :-	
Cavitation of pump	- (see Cavitation of pump)
Resonance of system	- Introduce flexible piping at critical points and/or fasten pipes
Unstable relief valve	- Check setting/examine. Replace as necessary
2. Insufficient Pressure in the System	
Symptoms	Remedy/Solution
Pump will not prime	- See 1a and 1b
Relief valve opening below setting.	- Adjust the setting using a pressure gauge, change Relief valve if necessary
Hydraulic motor/pump is worn or has excessive external damage	- Repair or replace unit
Lack of power from engine	- Examine for possible faults in system specification and engine management system
Pump has not been primed	- See pump installation instructions

Maintenance

3. Pump Deliveries Low or No Fluid

Symptoms	Remedy/Solution
Low oil level	- Examine for cause of loss of oil and top up
Suction line restricted or closed	- See 1a
Pump running in reverse	- Check rotation of pump and P.T.O.
Incorrect oil having too high a viscosity	- Change oil
P.T.O. running too slow	- Check speed

4. Erratic Operation of Motor

Symptoms	Remedy/Solution
Entrapped air causing fluctuating pump delivery	- Ensure that oil in system is clear from bubbles and foam (See 1a)
Inconsistent P.T.O. speed	- Check PTO spec, condition, engine speed & engine management system
Air pocket in system	- Remove air from system by bleeding

CAUTION

When handling hot Relief Valves wear heat resistant gloves.

5. Overheating

Symptoms	Remedy/Solution
Relief valve setting too low allowing oil by-pass directly to tank	- Adjust setting using a pressure gauge - See Setting Section
Radiator blocked with road dirt or obstructed reducing cooling	- Clean/remove obstruction
Radiator fan not working	- Replace fan motor/ investigate for fan interference
Hydraulic motor/pump is worn and has excessive internal leakage	- Repair or replace unit
Flow too high for Hydrapak (maximum 140 litres/min.)	- Reduce P.T.O. speed
Incorrect motor / pump type used	- Replace with higher efficiency equipment

NOTE

Only a small amount of water will cause this effect and will not result in short term system damage.

6. Oil Condition

Symptoms	Remedy/Solution
Oil looks milky (caused by water entering the system)	- Check for leaks, particularly in cooler

Maintenance

4.4 Spare Parts Diagrams

Item	Description	Part Number	Qty
1	Reservoir (Standard)	8901314	1
2	Filter Support	6460614	1
3	Filter Element	6828914	1
4	Retaining Washer	7924200	3
5	Radiator	8770314	1
6	Filter Retaining Nut	6701814	1
7	Strainer Disc	6289014	1
8	Sealing Ring	7080814	1
9	Filler Cap	626X614	1
10	Filter Tie Rod	8850814	1
11	Outer Cover	8842615	1
12	Radiator Outlet Hose	6471714	1
13	Radiator Inlet Hose	6471614	1
14	Hose Clip	H620070	4
15	St/St Hex Head M6 x 16	M470067016-7	3
16	M8 Dowty Washer	H790390	1
17	M8 Domed Nut	M230087000-2	1
18	Sightglass Kit	6482900	1
19	Fan Motor Assembly	H1656001	1
20	Cap Head Screw M6 x 22	M450067022-9	2
21	Fan Impeller	3301400	1
22	Adaptor 1/4" BSP	H6910200	1
23	Dowty Washer 1/4"	H7900200	1
24	Sealing Tape 6mm x 25mm x 1.5m	8820100	1
25	Motor Supply Pipe	6474400	1
***	- Motor Supply Pipe	6473600	1
26	Cover Securing Grommet	8251100	2
27	Spring	8871714	1
28	Serial No. pLate	6726200	1
#	29 Sight Glass Gasket	6405115	1
30	Polyhydron Valve Block Assembly	8501114	1
*	31 Radiator Support Grommet	8250914	2
32	Adaptor 1/4" BSP x 14mm	H6918800	1
33	Dowty Washer	H7904400	1
34	Copper Washer	7902100	2
35	Cork Gasket	6404915	1
36	Clamp Plate	8614214	1
**	37 Restrictor/Assy Filter	8023600	1
38	Fan Nut	6701714	1
39	M12 Plain Washers	M600120000-2	2
41	Grub Screw Special	SK894/14	1
#	42 'GD' Logo	6727914	1
43	Drive Screws	M510038006-2	2
*	44 Filter 'Blocking Indicator	H4122200	1
**	45 Bulkhead Fitting	6916800	1

Refer to page 21 for spares sheet1

* Standard Units Only

** High Pressure Units Only

*** Cryogenics only

Maintenance

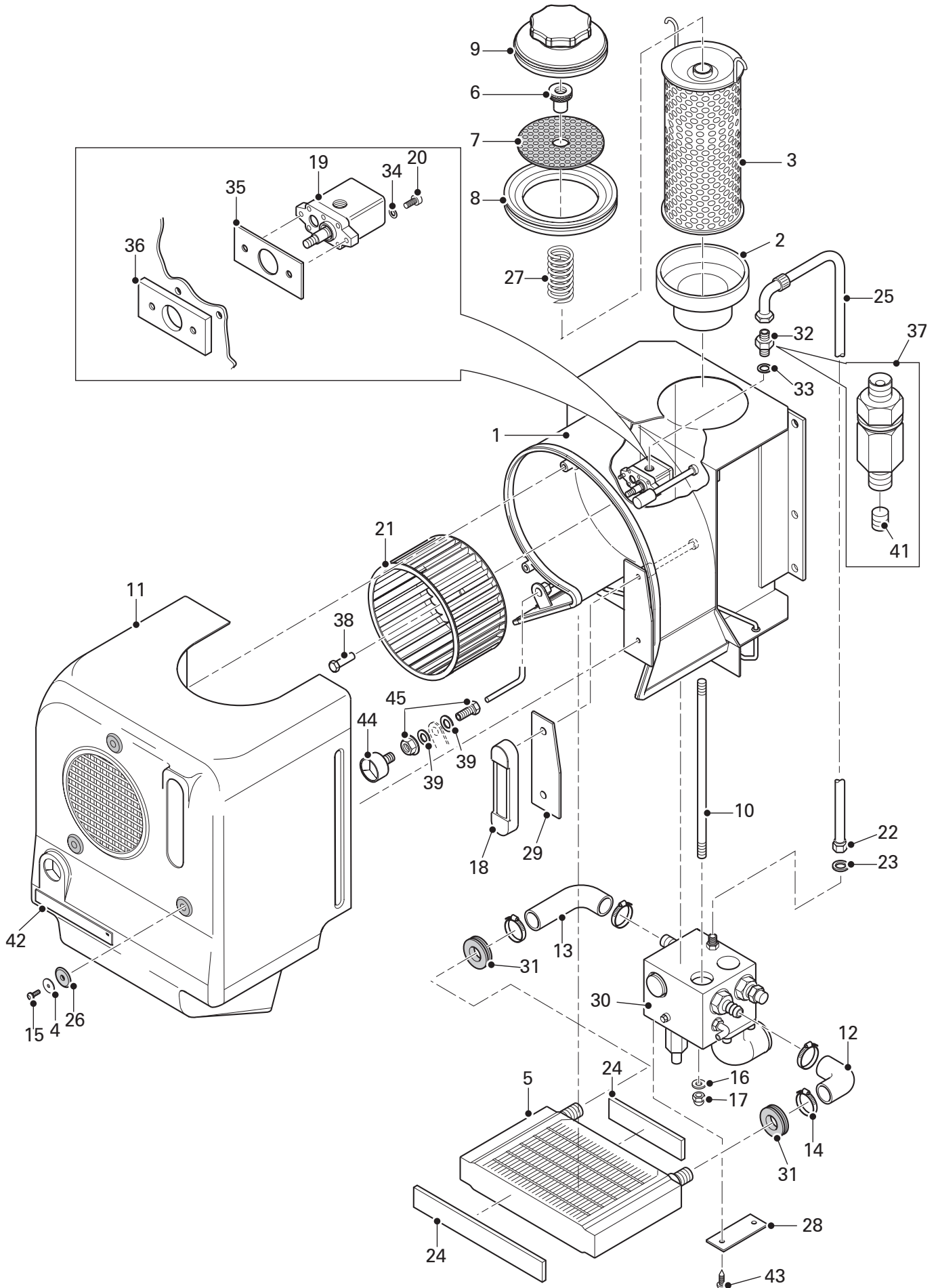

Maintenance

POLYHYDRON VALVE BLOCK

Item	Description	Part Number	Qty
1	This Item part of Hydrapak Reservoir.		
2	Plastic Plug	6952200.....	1
3	Plunger.....	5561214.....	1
4	Spring Retainer.....	6560514.....	1
5	Spring	8871800.....	1
6	Ferrule 3/4" BSP	6919100.....	2
7	Relief Valve	5004900.....	1
8	Flanged Plug 1/8" BSP	0400123000-2.....	6
9	Caphead Screw M8 x 20.....	M450087020-9	4
10	3/4" BSP Dowty Washer	H7900600	4
11	'O' Ring	6742800.....	1
12	Circlip.....	M140400000-5	1
13	'O' Ring	6742900.....	1
14	Drive Screws	M510038006-2	2
15	M8 Dowty Washer.....	H7903900	2
16	Suction Elbow - 1.25" (HK- **** -L) ...	6919014.....	
-	Suction Elbow - 1.50" (HK- **** -M) ...	6919314.....	
-	Suction Elbow - 2.00" (HK- **** -H)....	6919414.....	
17	M8 Domed Nut.....	M230087000-2	1
18	Nameplate	6726200.....	1
19	1/8" Dowty Washer	H7900100	1
20	Adaptor	6990300.....	1
21	Nylon Tube	H6950200	1
23	1/4" BSP Dowty Washer	H7900200	2
22	Blanking Cap 3/8" BSP	H7019400	1
24	1/4" Equal Adaptor.....	H6910200	1
25	Adaptor 3/4" x 3/8" BSP.....	H6913700	1

Maintenance

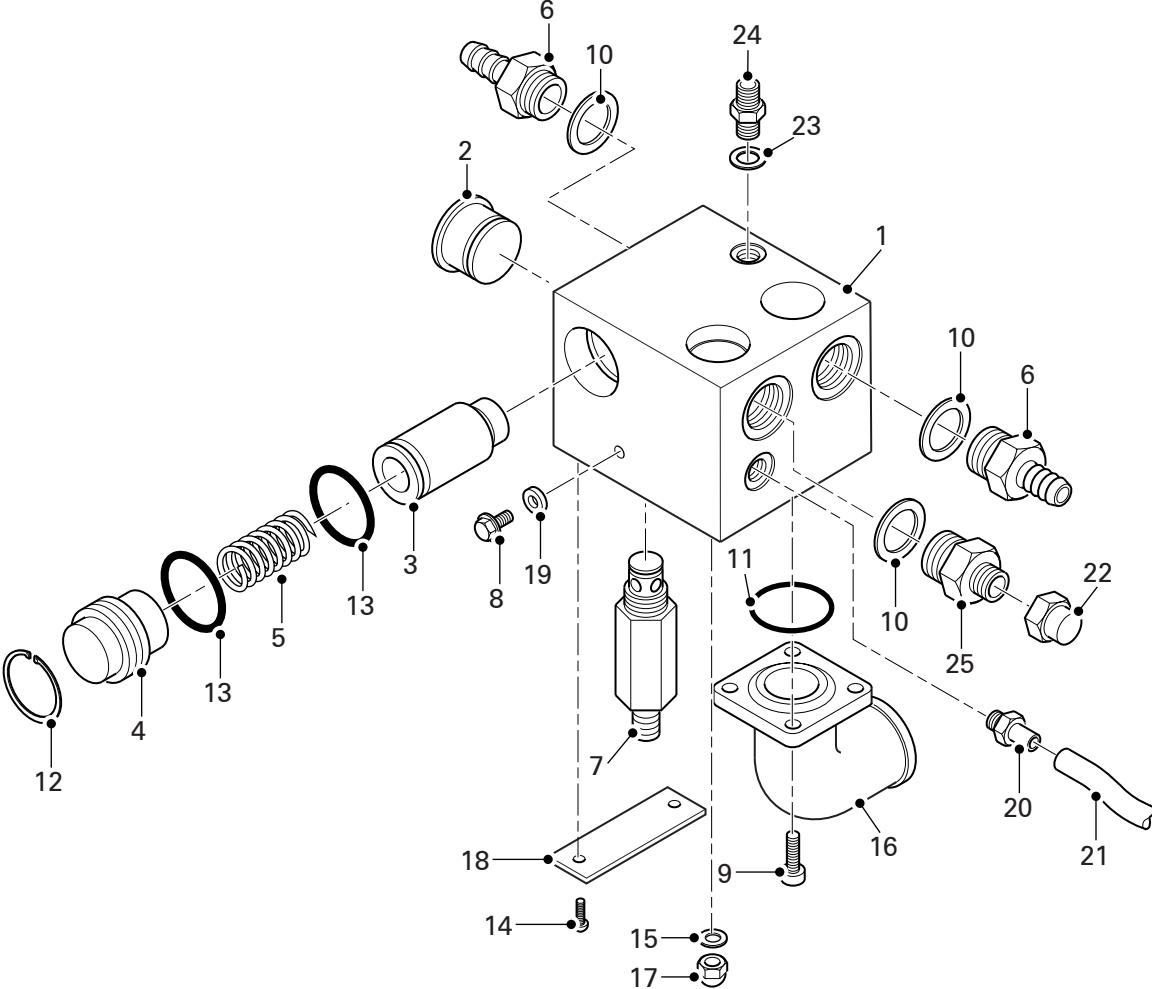

Contact Us

Americas

Gardner Denver, Inc.
Industrial Products Group - Americas
1800 Gardner Expressway
Quincy, IL. 62305
Toll Free: 1-800-682-9868
Phone: 217-222-5400
Fax: 217-221-8780

email: mobilesolutions@gardnerdenver.com

France

Gardner Denver France SA
Division Compresseurs
42, rue du Montmurier, BP 604
38070 Saint-Quentin-Fallavier, France
Phone: +33 (0)474941673
Fax: +33 (0)474941689

email: contact.lyon@gardnerdenver.com

UK Sales & Service

Gardner Denver UK Ltd
PO Box 468
Cross Lane, Tong
Bradford, West Yorkshire
United Kingdom
BD4 0SU
Phone: +44 (0)1274 683131
Fax: +44 (0)1274 651006

email: sales.uk@gardnerdenver.com

Australia

Gardner Denver Ind. Australia Pty Ltd
30 Bearing Road
Seven Hills
New South Wales
2147 Australia
Phone: +61 2 96207000
Fax: +61 2 96207955

email: hermant.malik@gardnerdenver.com

Germany

Gardner Denver Deutschland GmbH
Am Dorn 14
48308 Senden
Germany
Phone: +49 (0)253634840
Fax: +49 (0)25363484010

email: info.de@gardnerdenver.com

Spain

Gardner Denver Iberica S.L.
Calle Primavera, 20
Poligono Industrial Las Monjas
28850 Torrejon de Ardoz
Madrid, Spain
Phone: +34 (0)916560056
Fax: +34 (0)916770496

email: aurelio.fernandez@gardnerdenver.com

Belgium

Gardner Denver Belgium N.V.
Luithagen 7A
Haven 200
B-2030 Antwerpen
Belgium
Phone: +32 (0)3 5415040
Fax: +32 (0)3 5416509

email: info.be@gardnerdenver.com

Netherlands

Gardner Denver Nederland BV
Barwoutswaarder 3B
3449 He Woerden
The Netherlands
Phone: +31 (0)348410150
Fax: +31 (0)348418079

email: sales.nl@gardnerdenver.com

Rest of the World

Gardner Denver Ltd
PO Box 178
Springmill Street
Bradford, West Yorkshire
United Kingdom
BD5 7YH
Phone: +44 (0)1274 718100
Fax: +44 (0)1274 655272

email: gdtransportsales@gardnerdenver.com

For additional information, contact your local representative or

The logo for Gardner Denver, featuring the word "Gardner" in a large, bold, black sans-serif font, with a thick red horizontal line underneath it. Below the line, the word "Denver" is written in a smaller, bold, black sans-serif font.

Gardner Denver Ltd
PO Box 178,
Springmill Street,
Bradford,
West Yorkshire, UK
BD5 7YH

Tel: +44 (0)1274 718100

Fax: +44 (0)1274 655272

Email: gdtransportsales@gardnerdenver.com

Web: www.gd-transport.com