

Gardner
Denver[®]

OIL-FREE COMPRESSOR

GD150



The GD150 is a high flow, oil free, radial vane compressor for pressure off-loading of bulk liquids. The most modern materials and manufacturing methods make the GD150 Compressor the most reliable and durable vane compressor available.

- Pressure to 36 psig
- Flow rate to 75 cfm

Features & Benefits

- 100% oil free air for clean product unloading
- Corrosion resistant, stainless steel rotor will not corrode or de-plate like coated rotors
- Steel shafts for durability and strength
- Viton seals
- High temperature blades
- Lightweight and compact with anodized aluminum body and side plates
- Double ended shaft for clockwise or counter clockwise drive
- Hydraulic drive mounting trucks available for direct coupling of hydraulic motors



GD150 Performance & Dimensions

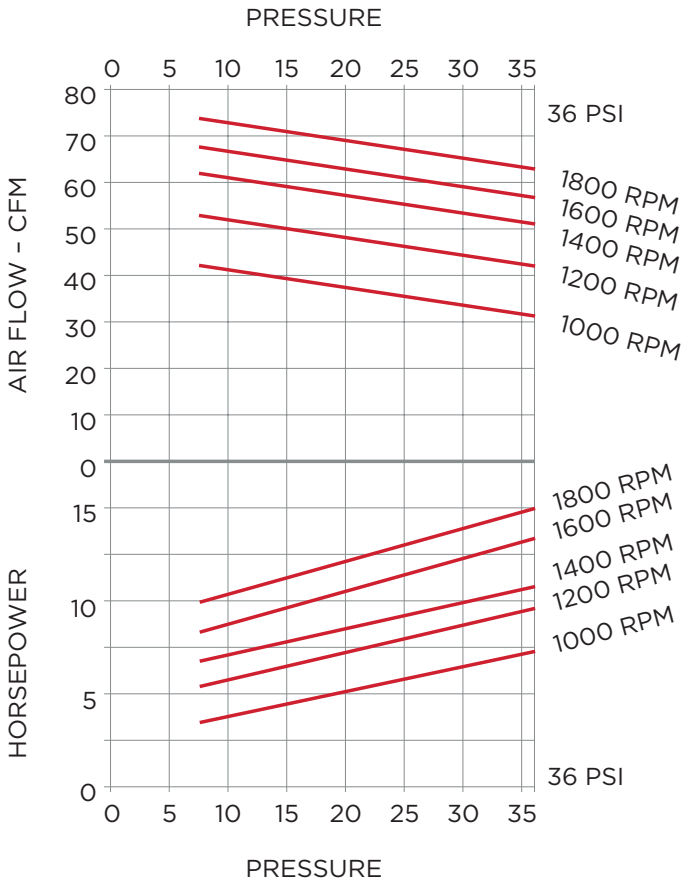

Accessories

The standard accessories supplied with the GD150 are:

- 1½" brass check valve
- Pressure relief valve 30 psi
- Detachable mounting feet
- Specially designed aluminum air filter
- 1½" NPTF port flanges

Options include:

- 1" stainless steel check valve
- Pressure relief valve 36 psi
- Drive flange
- 3 way ball valve
- Stainless steel mounting brackets

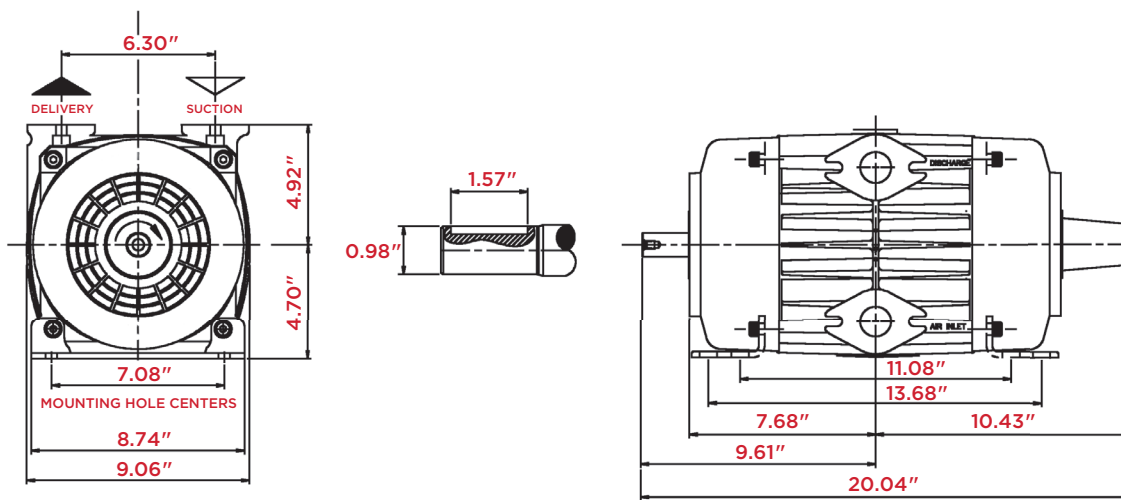

The leader in every market we serve
by continuously improving all business processes
with a focus on innovation and velocity

Gardner
Denver[®]

www.GardnerDenver.com

©2024 Industrial Technologies and Services, LLC
Printed in U.S.A.
GDT-GD150 3rd Ed. 7/24

